

IEM 电预塑马达



NINGBO OIL CONTROL HYDRAULIC CO., LTD.
NINGBO INTERMOT HYDRAULIC MOTOR CO., LTD.

intermot

在全球环保形势下，为早日实现“碳达峰”、“碳中和”战略目标，电气化成为绿色低碳转型的重要路径之一。宁波欧易液压公司为适应塑机市场的需求，推出IEM系列电预塑马达。IEM系列电预塑马达具有精确度高、节能、增效等优点，可直接替代注塑机预塑单元的液压传动。

产品特点

- ◆ 采用大扭矩、大功率伺服电机进行驱动，程序通过驱动器对电机进行控制，编码器精确反馈马达的转速和位置，起动扭矩大，定位精度高。
- ◆ 减速器采用斜齿轮，震动和噪音小，传动效率高，轴向尺寸短，运动惯量小。高精度的齿轮和强度结构，使用寿命长。
- ◆ 伺服电机和减速器采用油冷结构，壳体内设置冷却流道，通过冷却油，保证减速机可以长时间稳定运转。
- ◆ 减速机采用模块化设计，可与不同扭矩、转速的伺服电机配合，可供使用时精准选择。

产品标识说明

IEM 1 - 2 - 3 / 4 - 5 / 6 - 7 - 01

1	2	3	4	5	6	7	8
结构代码	减速机代号	最大输出 扭矩	轴伸形式	最大输出 转速	减速比	冷却方式	设计代码
1: 外置式行星齿轮减速箱 2: 内置式行星齿轮减速箱 3: 平行轴式齿轮减速箱 4: 同步减速带式 5: 电直驱一体式	03: 对应 NHM3 液压马达 06: 对应 NHM6 液压马达 08: 对应 NHM8 液压马达 11: 对应 NHM11 液压马达 16: 对应 NHM16 液压马达 31: 对应 NHM31 液压马达 200: 对应 FMB200 液压马达 270: 对应 FMB270 液压马达 325: 对应 FMB325 液压马达	见参数表	A: 标准矩形外花键 B: 标准平键 其他形式请与我司技术人员沟通	见参数表	见参数表	Y: 油冷 F: 风冷 S: 水冷 Z: 自冷	01 (可省略) 02 ⋮

IEM1-***-01系列技术参数 (高速型)

规格型号	适应吨位 (T)	最大螺杆直径 (普通塑料) mm	螺杆扭矩 (N.m)	最大输出转速 (rpm)	减速机最大输出扭矩 (N.m)	驱动器额定功率 (kW)	电机额定功率 (kW)	电机额定转速 (rpm)	电机最高转速 (rpm)	减速比	对应欧易公司液压马达规格
IEM1-03-750/*-400/6.25-Y	80-230	45	600	400	750	18	15.7	2000	2500	6.25	NHM3及相同止口马达
IEM1-06-1400/*-400/6.25-Y	160-260	60	1265	400	1400	30	29.3	2000	2500	6.25	NHM6及相同止口马达
IEM1-08-2000/*-300/8-Y	260-500	70	1889	300	2000	35	35.6	2000	2400	8	NHM8及相同止口马达
IEM1-11-3000/*-280/8-Y	320-600	80	2674	280	3000	45	48.1	2000	2250	8	NHM11及相同止口马达
IEM1-16-4000/*-220/10-Y	400-750	90	3632	220	4000	55	52.3	2000	2200	10	NHM16及相同止口马达
IEM1-31-6000/*-210/10-Y	500-800	100	4777	210	6000	55	66.7	1700	2100	10	NHM31及相同止口马达
IEM1-200-6500/*-210/10-Y	800-1000	110	6120	210	6500	75	71.2	1700	2100	10	FMB200及相同止口马达
IEM1-270-8000/*-170/10-Y	800-1000	120	7674	170	8000	75	78.5	1500	1700	10	FMB270及相同止口马达

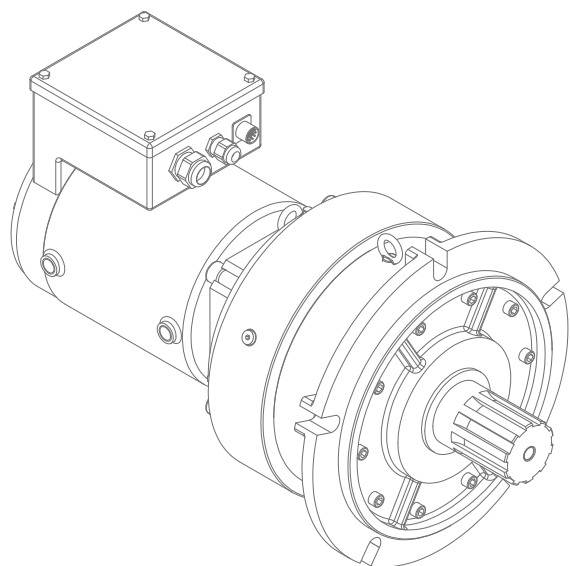

IEM1-***-01系列技术参数 (普通型)

规格型号	适应吨位 (T)	最大螺杆直径 (普通塑料) mm	螺杆扭矩 (N.m)	最大输出转速 (rpm)	减速机最大输出扭矩 (N.m)	驱动器额定功率 (kW)	电机额定功率 (kW)	电机额定转速 (rpm)	电机最高转速 (rpm)	减速比	对应欧易公司 液压马达规格
IEM1-03-750/*-250/8.5-Y	80-140	45	600	250	750	11	8.9	1700	2100	8.5	NHM3及相同止口马达
IEM1-03-750/*-290/8.5-Y	80-140	45	600	290	750	11	10	2000	2500	8.5	NHM3及相同止口马达
IEM1-06-1400/*-220/9.5-Y	150-230	60	1265	220	1400	18	14.6	1700	2100	9.5	NHM6及相同止口马达
IEM1-06-1400/*-260/9.5-Y	150-230	60	1265	260	1400	18	17	2000	2500	9.5	NHM6及相同止口马达
IEM1-08-2000/*-220/9.5-Y	240-320	70	1890	220	2000	22	21	1700	2100	9.5	NHM8及相同止口马达
IEM1-08-2000/*-260/9.5-Y	240-320	70	1890	260	2000	22	25	2000	2500	9.5	NHM8及相同止口马达
IEM1-11-3000/*-220/9.5-Y	300-400	80	2674	220	3000	30	30	1700	2100	9.5	NHM11及相同止口马达
IEM1-11-3000/*-260/9.5-Y	300-400	80	2674	260	3000	30	36	2000	2500	9.5	NHM11及相同止口马达
IEM1-16-4500/*-210/10-Y	400-500	90	3632	210	4500	45	42	1700	2100	10	NHM16及相同止口马达
IEM1-16-4500/*-250/10-Y	400-500	90	3632	250	4500	45	48	2000	2500	10	NHM16及相同止口马达
IEM1-31-6500/*-155/13.5-Y	500-750	105	5423	155	6500	55	52	1700	2100	13.5	NHM31及相同止口马达
IEM1-31-6500/*-170/13.5-Y	500-750	105	5423	170	6500	55	60	2000	2500	13.5	NHM31及相同止口马达
IEM1-31-7000/*-155/10-Y	500-750	105	5423	155	7000	55	61.2	1300	1500	10	NHM31及相同止口马达
IEM1-31-7000/*-170/10-Y	500-750	105	5423	170	7000	75	70.6	1500	1700	10	NHM31及相同止口马达
IEM1-200-7000/*-155/13.5-Y	500-750	105	5423	155	7000	55	52	1700	2100	13.5	FMB200及相同止口马达
IEM1-200-7000/*-170/13.5-Y	500-750	105	5423	170	7000	55	60	2000	2300	13.5	FMB200及相同止口马达
IEM1-200-7000/*-150/10-Y	500-750	105	5427	150	7000	55	52	1300	1500	10	FMB200及相同止口马达
IEM1-200-7000/*-170/10-Y	500-750	105	5427	170	7000	75	70.6	1500	1700	10	FMB200及相同止口马达
IEM1-270-9000/*-130/16-Y	800-1000	120	8533	130	9000	75	65	1700	2100	16	FMB270及相同止口马达
IEM1-270-9000/*-170/16-Y	800-1000	120	8533	170	9000	75	71.2	2000	2300	16	FMB270及相同止口马达
IEM1-270-10000/*-140/10-Y	800-1000	125	8533	140	10000	75	81.6	1200	1400	10	FMB270及相同止口马达
IEM1-270-10000/*-170/10-Y	800-1000	125	8533	170	10000	110	102	1500	1700	10	FMB270及相同止口马达
IEM1-325-9500/*-145/8.8-Y	800-1000	120	8533	145	9500	90	81.6	1200	1300	8.8	FMB325及相同止口马达
IEM1-325-9500/*-170/8.8-Y	800-1000	120	8533	170	9500	110	102	1500	1500	8.8	FMB325及相同止口马达
IEM1-325-12000/*-135/8.8-Y	1000-1200	135	11300	135	12000	110	107	1200	1200	8.8	FMB325及相同止口马达
IEM1-325-12000/*-170/8.8-Y	1000-1200	135	11300	170	12000	130	134	1500	1500	8.8	FMB325及相同止口马达
IEM1-325-15000/*-135/8.8-Y	1100-1300	145	13500	135	15000	110	107	1200	1200	8.8	FMB325及相同止口马达
IEM1-325-15000/*-170/8.8-Y	1100-1300	145	13500	170	15000	130	134	1500	1500	8.8	FMB325及相同止口马达

IEM1-***-01系列外形安装尺寸 (标准矩形外花键)

规格型号	A	B	C	D	E	F	G	H	I	K	n-φd	Ga	Gb	Z-D×d×b
IEM1-03-750/A-250/8.5-Y	470.5	257	317	210	190	79	13	57	38	18	5-φ13	\	4-G3/8"	8-38b12×32b12×6f8
IEM1-03-750/A-290/8.5-Y	470.5	257	317	210	190	79	13	57	38	18	5-φ13	\	4-G3/8"	8-38b12×32b12×6f8
IEM1-06-1400/A-220/9.5-Y	550	285	340	254	230	90	14	68	46	20	5-φ16	\	4-G3/8"	8-42b12×36b12×7f8
IEM1-06-1400/A-260/9.5-Y	550	285	340	254	230	90	14	68	46	20	5-φ16	\	4-G3/8"	8-42b12×36b12×7f8
IEM1-08-2000/A-220/9.5-Y	564	372	422	300	256	102.5	15	75	50	25	5-φ17	2-G3/8"	4-G3/8"	8-50b12×46b12×9f8
IEM1-08-2000/A-260/9.5-Y	564	372	422	300	256	102.5	15	75	50	25	5-φ17	2-G3/8"	4-G3/8"	8-50b12×46b12×9f8
IEM1-11-3000/A-220/9.5-Y	604	372	422	300	256	102.5	15	75	50	25	5-φ17	2-G3/8"	4-G3/8"	8-50b12×46b12×9f8
IEM1-11-3000/A-260/9.5-Y	604	372	422	300	256	102.5	15	75	50	25	5-φ17	2-G3/8"	4-G3/8"	8-50b12×46b12×9f8
IEM1-16-4500/A-210/10-Y	702	475	439	327	301.5	148	18	100	65	32	5-φ21	2-G3/8"	4-G3/8"	8-72b12×62b12×12f8
IEM1-16-4500/A-250/10-Y	702	475	439	327	301.5	148	18	100	65	32	5-φ21	2-G3/8"	4-G3/8"	8-72b12×62b12×12f8
IEM1-31-6500/A-155/13.5-Y	851	475	491	420	380	166	20	134	80	40	5-φ25	2-G1/2"	4-G1/2"	10-92b12×82b12×12f8
IEM1-31-6500/A-170/13.5-Y	851	475	491	420	380	166	20	134	80	40	5-φ25	2-G1/2"	4-G1/2"	10-92b12×82b12×12f8
IEM1-31-7000/A-155/10-Y	837.5	475	552	420	381	166.5	20	110	80	35	5-φ25	2-G1/2"	4-G1/2"	10-92b12×82b12×12f8
IEM1-31-7000/A-170/10-Y	837.5	475	552	420	381	166.5	20	110	80	35	5-φ25	2-G1/2"	4-G1/2"	10-92b12×82b12×12f8
IEM1-200-7000/A-155/13.5-Y	815	475	491	419.1	381	130	20	98	76	40	5-φ21	2-G1/2"	4-G1/2"	DIN5480 W55×3×17×7h
IEM1-200-7000/A-170/13.5-Y	815	475	491	419.1	381	130	20	98	76	40	5-φ21	2-G1/2"	4-G1/2"	DIN5480 W55×3×17×7h
IEM1-200-7000/A-150/10-Y	800	475	552	491.1	381	129.6	20	97.6	76	35	5-φ21	2-G1/2"	4-G1/2"	DIN5480 W55×3×17×7h
IEM1-200-7000/A-170/10-Y	800	475	552	491.1	381	129.6	20	97.6	76	35	5-φ21	2-G1/2"	4-G1/2"	DIN5480 W55×3×17×7h
IEM1-270-9000/A-130/16-Y	860	570	570	520.7	457	140	24	103	76	32	7-φ21	2-G1/2"	4-G1/2"	DIN5480 W55×3×17×7h
IEM1-270-9000/A-170/16-Y	860	570	570	520.7	457	140	24	103	76	32	7-φ21	2-G1/2"	4-G1/2"	DIN5480 W55×3×17×7h
IEM1-270-10000/A-140/10-Y	904	570	655	520.7	457	138.6	24	101.6	76	35	7-φ21	2-G1/2"	4-G1/2"	DIN5480 W55×3×17×7h
IEM1-270-10000/A-170/10-Y	904	570	655	520.7	457	138.6	24	101.6	76	35	7-φ21	2-G1/2"	4-G1/2"	DIN5480 W55×3×17×7h
IEM1-325-9500/A-145/8.8-Y	874	572	656	520.7	457	138.6	24	101.6	76	35	7-φ21	2-G1/2"	4-G1/2"	DIN5480 W55×3×17×7h
IEM1-325-9500/A-170/8.8-Y	874	572	656	520.7	457	138.6	24	101.6	76	35	7-φ21	2-G1/2"	4-G1/2"	DIN5480 W55×3×17×7h
IEM1-325-12000/A-135/8.8-Y	924	572	656	520.7	457	138.6	24	101.6	76	35	7-φ21	2-G1/2"	4-G1/2"	DIN5480 W55×3×17×7h
IEM1-325-12000/A-170/8.8-Y	924	572	656	520.7	457	138.6	24	101.6	76	35	7-φ21	2-G1/2"	4-G1/2"	DIN5480 W55×3×17×7h
IEM1-325-15000/A-135/8.8-Y	974	572	656	520.7	457	138.6	24	101.6	76	35	7-φ21	2-G1/2"	4-G1/2"	DIN5480 W55×3×17×7h
IEM1-325-12000/A-170/8.8-Y	974	572	656	520.7	457	138.6	24	101.6	76	35	7-φ21	2-G1/2"	4-G1/2"	DIN5480 W55×3×17×7h

IEM1-***-01系列外形安装尺寸(标准平键)

规格型号	A	B	C	D	E	F	G	H	I	J	K	L	M	N	φd1	n-φd2	Ga	Gb
IEM1-03-750/B-250/8.5-Y	470	257	317	210	190	79	13	57	45	5	18	33	10	8	φ38	5-φ13	\	4-G3/8"
IEM1-03-750/B-290/8.5-Y	470	257	317	210	190	79	13	57	45	5	18	33	10	8	φ38	5-φ13	\	4-G3/8"
IEM1-06-1400/B-220/9.5-Y	550	285	340	254	230	90	14	68	50	5	20	37	12	8	φ42	5-φ16	\	4-G3/8"
IEM1-06-1400/B-260/9.5-Y	550	285	340	254	230	90	14	68	50	5	20	37	12	8	φ42	5-φ16	\	4-G3/8"
IEM1-08-2000/B-220/9.5-Y	584	372	422	300	256	122.5	15	90	80	5	25	48	14	9	φ54	5-φ17	2-G3/8"	4-G3/8"
IEM1-08-2000/B-260/9.5-Y	584	372	422	300	256	122.5	15	90	80	5	25	48	14	9	φ54	5-φ17	2-G3/8"	4-G3/8"
IEM1-11-3000/B-220/9.5-Y	624	370	422	300	256	122.5	15	90	80	5	25	48	14	9	φ54	5-φ17	2-G3/8"	4-G3/8"
IEM1-11-3000/B-260/9.5-Y	624	370	422	300	256	122.5	15	90	80	5	25	48	14	9	φ54	5-φ17	2-G3/8"	4-G3/8"
IEM1-16-4500/B-210/10-Y	725	475	439	327	301.5	170	18	110	100	5	32	65	18	11	φ72	5-φ21	2-G3/8"	4-G3/8"
IEM1-16-4500/B-250/10-Y	725	475	439	327	301.5	170	18	110	100	5	32	65	18	11	φ72	5-φ21	2-G3/8"	4-G3/8"
IEM1-31-6500/B-155/13.5-Y	852	475	491	420	380	166	20	130	120	5	40	76	24	14	φ85	5-φ25	2-G1/2"	4-G1/2"
IEM1-31-6500/B-170/13.5-Y	852	475	491	420	380	166	20	130	120	5	40	76	24	14	φ85	5-φ25	2-G1/2"	4-G1/2"
IEM1-31-7000/B-155/10-Y	836	475	552	420	381	165	20	134	125	4	35	76	24	14	φ85	5-φ25	2-G1/2"	4-G1/2"
IEM1-31-7000/B-170/10-Y	836	475	552	420	381	165	20	134	125	4	35	76	24	14	φ85	5-φ25	2-G1/2"	4-G1/2"
IEM1-200-7000/B-155/13.5-Y	852	475	491	419.1	381	166	20	134	125	4	40	77	24	16	φ85	5-φ21	2-G1/2"	4-G1/2"
IEM1-200-7000/B-170/13.5-Y	852	475	491	419.1	381	166	20	134	125	4	40	77	24	16	φ85	5-φ21	2-G1/2"	4-G1/2"
IEM1-200-7000/B-150/10-Y	836	475	552	491.1	381	165	20	134	125	4	35	77	24	16	φ85	5-φ21	2-G1/2"	4-G1/2"
IEM1-200-7000/B-170/10-Y	836	475	552	491.1	381	165	20	134	125	4	35	77	24	16	φ85	5-φ21	2-G1/2"	4-G1/2"
IEM1-270-9000/B-130/16-Y	910	570	570	520.7	457	190	24	153	140	5	32	77	24	16	φ85	7-φ21	2-G1/2"	4-G1/2"
IEM1-270-9000/B-170/16-Y	910	570	570	520.7	457	190	24	153	140	5	32	77	24	16	φ85	7-φ21	2-G1/2"	4-G1/2"
IEM1-270-10000/B-140/10-Y	952	570	655	520.7	457	187	24	153	140	5	35	77	24	16	φ85	7-φ21	2-G1/2"	4-G1/2"
IEM1-270-10000/B-170/10-Y	952	570	655	520.7	457	187	24	153	140	5	35	77	24	16	φ85	7-φ21	2-G1/2"	4-G1/2"
IEM1-325-9500/B-145/8.8-Y	922	572	656	520.7	457	187	24	165	140	5	35	77	24	16	φ85	7-φ21	2-G1/2"	4-G1/2"
IEM1-325-9500/B-170/8.8-Y	922	572	656	520.7	457	187	24	165	140	5	35	77	24	16	φ85	7-φ21	2-G1/2"	4-G1/2"
IEM1-325-12000/B-135/8.8-Y	972	572	656	520.7	457	187	24	165	140	5	35	77	24	16	φ85	7-φ21	2-G1/2"	4-G1/2"
IEM1-325-12000/B-170/8.8-Y	972	572	656	520.7	457	187	24	165	140	5	35	77	24	16	φ85	7-φ21	2-G1/2"	4-G1/2"
IEM1-325-15000/B-135/8.8-Y	1022	572	656	520.7	457	187	24	165	140	5	35	77	24	16	φ85	7-φ21	2-G1/2"	4-G1/2"
IEM1-325-12000/B-170/8.8-Y	1022	572	656	520.7	457	187	24	165	140	5	35	77	24	16	φ85	7-φ21	2-G1/2"	4-G1/2"

IEM1-***-01系列标准矩形外花键安装连接尺寸图

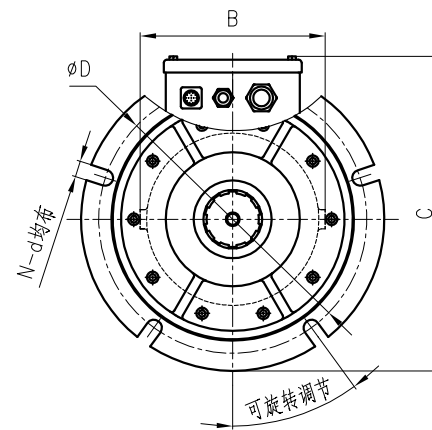
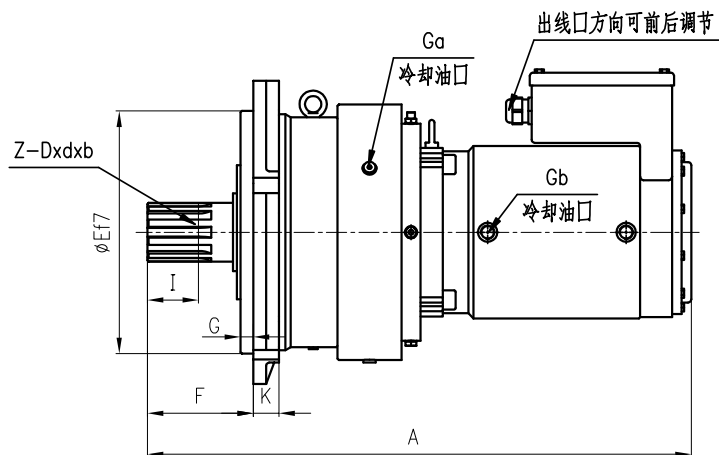

IEM1-***-01系列标准平键安装连接尺寸图

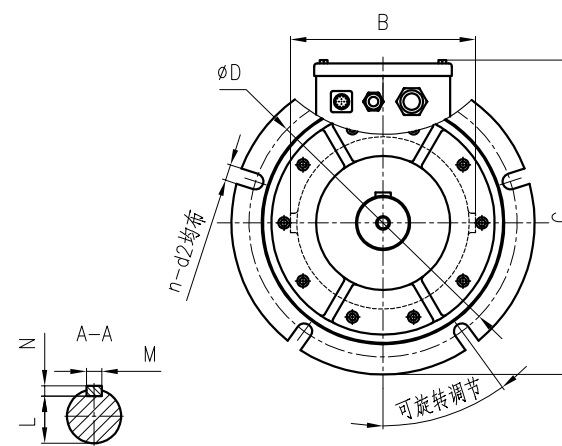
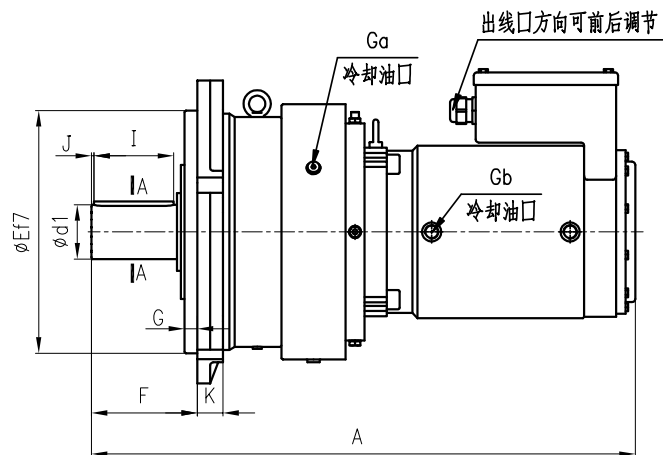

IEM1-***-02系列技术参数

规格型号	最大输出转速 (rpm)	减速机最大输出 扭矩 (N.m)	减速比	电机额定功率 (kW)	电机额定转速 (rpm)	电机额定频率 (Hz)	电机额定电流 (A)	反电势 (V)	电机额定电压 (V)	极数	对应欧易公司 液压马达规格
IEM1-08-1800/*-300/5.04-Y-02	300	1800	5.04	59	1500	100	112.4	308	380	8	8系列及相同止口马达
IEM1-11-2600/*-280/5.37-Y-02	280	2600	5.37	73.5	1500	100	139	331	380	8	11系列及相同止口马达
IEM1-16-3300/*-180/5.68-Y-02	180	3300	5.68	60.7	1000	100	110	335	380	8	16系列及相同止口马达
IEM1-16-3680/*-180/5.68-Y-02	180	3680	5.68	68	1000	100	115	366	380	8	16系列及相同止口马达
IEM1-16-4000/*-180/5.68-Y-02	180	4000	5.68	78.5	1000	100	144	322	380	8	16系列及相同止口马达
IEM1-31-6060/*-160/6.35-Y-02	160	6060	6.35	100	1000	100	174	341	380	8	31系列及相同止口马达
IEM1-31-7000/*-160/6.35-Y-02	160	7000	6.35	118	1000	100	215	335	380	8	31系列及相同止口马达

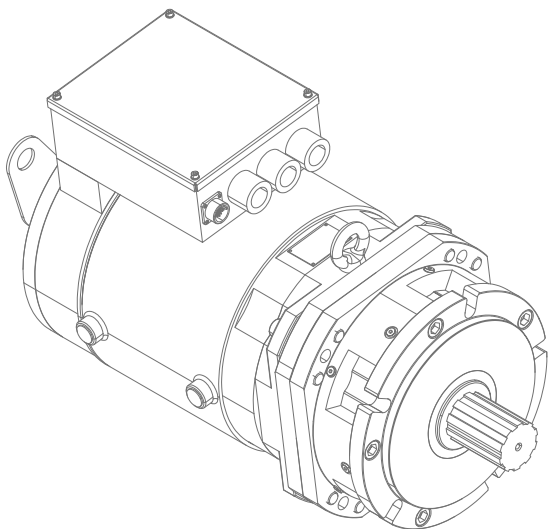

IEM1-***-02系列外形安装尺寸 (标准矩形外花键)

规格型号	A	B	C	D	E	F	G	I	K	d	Ga	Gb	Z-D × d × b
IEM1-08-1800/A-300/5.04 -Y-02	826	350	406	300	256	103	15	50	25	17	M22X1.5	Rc3/4"	8-38b12 × 32b12 × 6f8
IEM1-11-2600/A-280/5.37 -Y-02	827	350	406	300	256	103	15	50	25	17	M22X1.5	Rc3/4"	8-46b12 × 50b12 × 9f8
IEM1-16-3300/A-180/5.68 -Y-02	808	440	536	327	301.5	148	18	65	29	22	M27X2	Rc3/4"	8-62b12 × 72d11 × 12f8
IEM1-16-3680/A-180/5.68 -Y-02	860	440	536	327	301.5	148	18	65	29	22	M27X2	Rc3/4"	8-62b12 × 72d11 × 12f8
IEM1-16-4000/A-180/5.68 -Y-02	860	440	536	327	301.5	148	18	65	29	22	M27X2	Rc3/4"	8-62b12 × 72d11 × 12f8
IEM1-31-6060/A-160/6.35 -Y-02	972.5	440	536	420	380	166.5	14	80	32	25	M27X2	Rc3/4"	10-82b12 × 92b12 × 12f8
IEM1-31-7000/A-160/6.35 -Y-02	1024.5	440	536	420	380	166.5	14	80	32	25	M27X2	Rc3/4"	10-82b12 × 92b12 × 12f8

IEM1-***-02系列外形安装尺寸 (标准平键)

规格型号	A	B	C	D	E	F	G	I	J	K	L	M	N	d1	d2	Ga	Gb
IEM1-08-1800/B-300/5.04 -Y-02	846	350	406	300	256	123	15	80	5	25	48	14	9	54	17	M22X1.5	Rc3/4"
IEM1-11-2600/B-280/5.37 -Y-02	847	350	406	300	256	123	15	80	5	25	48	14	9	54	17	M22X1.5	Rc3/4"
IEM1-16-3300/B-180/5.68 -Y-02	830	440	536	327	301.5	160	18	100	5	29	64.5	18	11	72	22	M27X2	Rc3/4"
IEM1-16-3680/B-180/5.68 -Y-02	882	440	536	327	301.5	160	18	100	5	29	64.5	18	11	72	22	M27X2	Rc3/4"
IEM1-16-4000/B-180/5.68 -Y-02	882	440	536	327	301.5	160	18	100	5	29	64.5	18	11	72	22	M27X2	Rc3/4"
IEM1-31-6060/B-160/6.35 -Y-02	994.5	440	536	420	380	166.5	14	120	5	32	76	24	14	85	25	M27X2	Rc3/4"
IEM1-31-7000/B-160/6.35 -Y-02	1024.5	440	536	420	380	166.5	14	120	5	32	76	24	14	85	25	M27X2	Rc3/4"

IEM1-***-02系列标准矩形外花键安装连接尺寸图

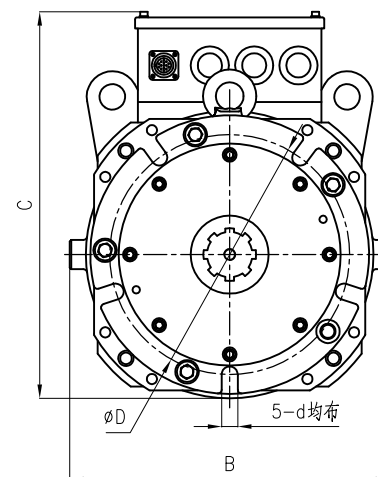
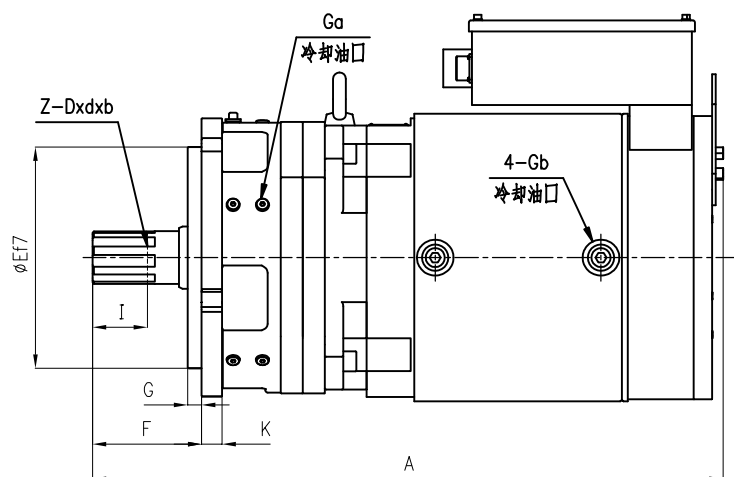

IEM1-***-02系列标准平键安装连接尺寸图

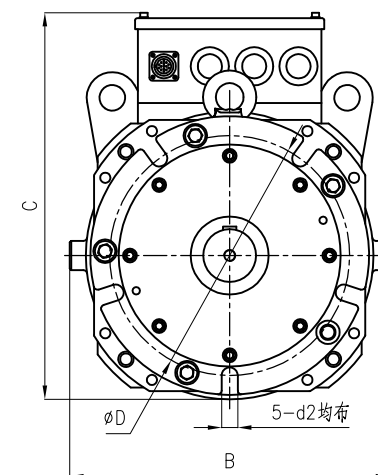
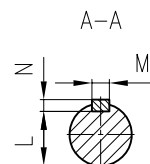
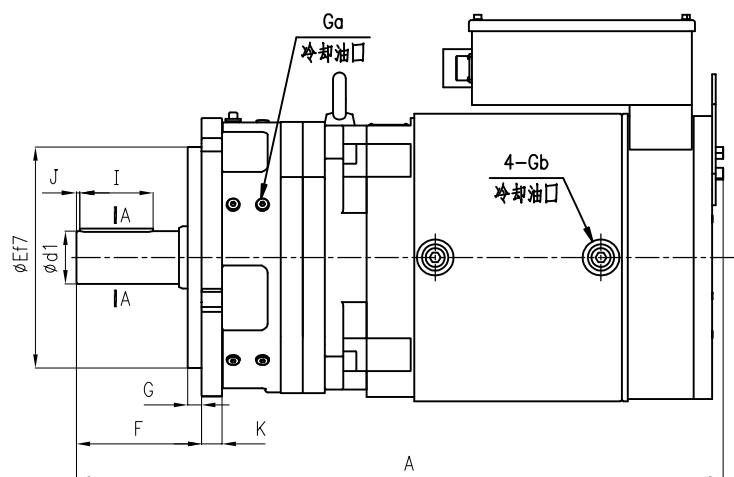

IEM3-***-01系列技术参数

型号	输出扭矩 (Nm)	输出转速 (rpm)	减速比	电机额定功率 (kW)	电机额定转速 (rpm)	电机额定频率 (Hz)	电机额定电流(A)	反电势 (V)	电机额定电压(V)	极数	重量(kg)	注油量(L)
IEM3-06-1300/*-320/6.3-S	1300	320	6.21	43.6	2000	133	87.2	301	380	8	85	7
IEM3-08-2100/*-250/8-S	2100	250	8.06	55.5	2000	133	106.6	313	380	8	150	10
IEM3-11-2940/*-210/8-S	2940	210	8.06	65	1700	113.3	131.2	298	380	8	165	10
IEM3-16-4000/*-155/12.5-S	4000	155	12.66	66	2000	133	132.1	301	380	8	300	20
IEM3-31-5300/*-155/12.5-S	5300	155	12.66	88.4	2000	133	176.9	301	380	8	350	20
IEM3-31-7400/*-125/16-S	7400	125	15.9	98.4	2000	133	197	301	380	8	560	40
IEM3-200-10500/*-125/16-S	10500	125	15.9	138.2	2000	200	257.5	330	380	12	560	40
IEM3-270-12500/*-125/16-S	12500	125	15.9	167.5	2000	200	312	330	380	12	600	40
IEM3-325-16100/*-100/20-S	16100	100	20.15	167.5	2000	200	362	327	380	12	1000	100

IEM3-***-01系列外形安装尺寸

型号	A	B	C	D	E	F
IEM3-06-1300/*-320/6.3-S	274	182	229	117	112	454
IEM3-08-2100/*-250/8-S	338	210	288	148	150	560
IEM3-11-2940/*-210/8-S	343	212	288	148	148	560
IEM3-16-4000/*-155/12.5-S	410	280	350	175	190	700
IEM3-31-5300/*-155/12.5-S	410	280	350	175	190	700
IEM3-31-7400/*-125/16-S	525	350	430	215	240	865
IEM3-200-10500/*-125/16-S	525	350	430	215	240	865
IEM3-270-12500/*-125/16-S	527	350	430	215	240	865
IEM3-325-16100/*-100/20-S	645	420	530	265	290	1060

IEM3-***-01系列外形图

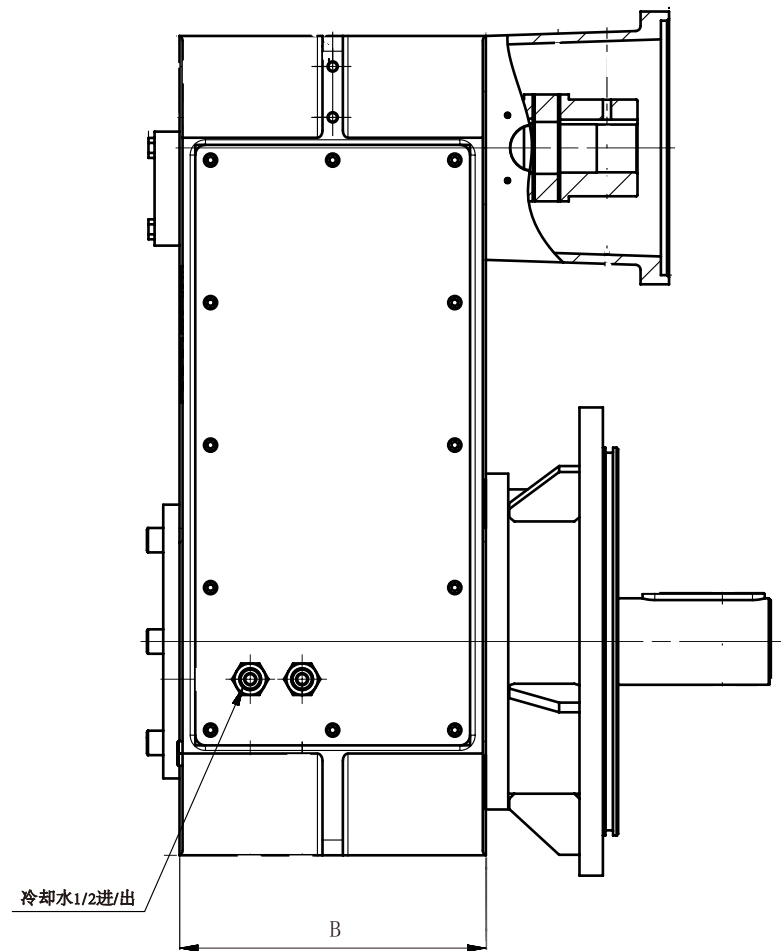
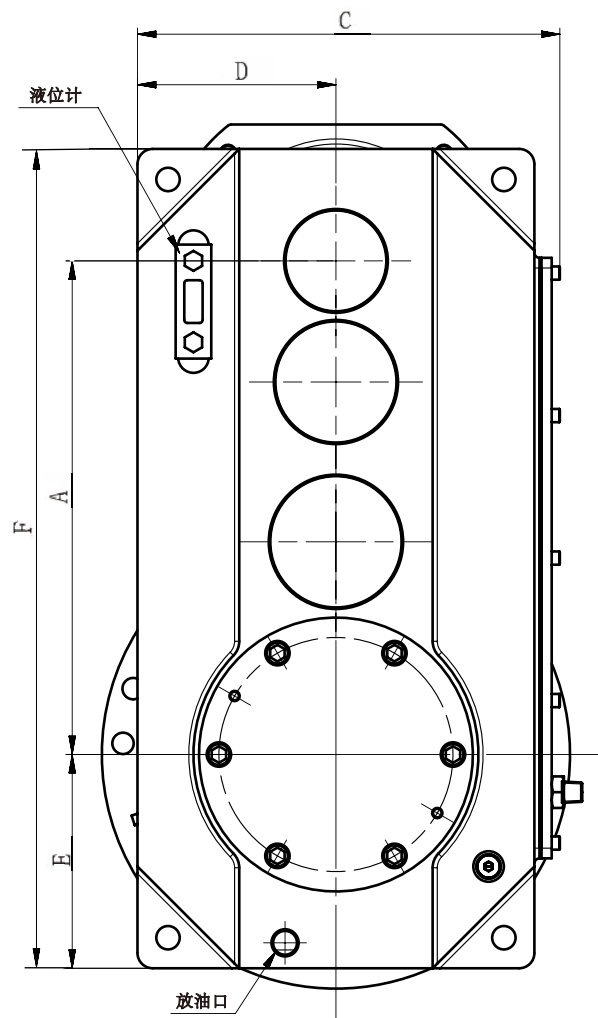

IEM5-***-01系列技术参数

型号	额定功率 (kW)	额定扭矩 (Nm)	额定电流 (A)	额定转速 (rpm)	额定频率 (Hz)	电压常数 (V/krpm)	电压等级 (V)	极数	长度L (mm)	适用减速机代号
IEM5-**-400/**-300-S-01	12.6	400	27.5	300	105	1062	380	42	326.5	03\06\08\11
IEM5-**-400/**-400-S-01	16.8	400	36.5	400	140	801	380	42	326.5	
IEM5-**-500/**-300-S-01	15.7	500	34	300	105	1071	380	42	358.5	
IEM5-**-500/**-400-S-01	20.9	500	46.1	400	140	792	380	42	358.5	
IEM5-**-600/**-300-S-01	18.8	600	42	300	105	1051	380	42	390.5	
IEM5-**-600/**-200-S-01	25.1	600	55	200	140	802	380	42	390.5	
IEM5-**-500/**-300-S-01	15.7	500	34	300	140	1081	380	56	289	03\06\08\11 \16
IEM5-**-500/**-400-S-01	20.9	500	45	400	186.7	807	380	56	289	
IEM5-**-700/**-300-S-01	22	700	47	300	140	1110	380	56	289	
IEM5-**-700/**-400-S-01	29.3	700	62.5	400	186.7	821	380	56	289	
IEM5-**-1000/**-300-S-01	31.4	1000	70	300	140	1060	380	56	339	
IEM5-**-1500/**-200-S-01	31.4	1500	70	200	93.3	1574	380	56	439	
IEM5-**-2270/**-150-S-01	35.7	2270	82.5	150	70	2093	380	56	504	16\31
IEM5-**-2270/**-200-S-01	47.5	2270	110	200	93.3	1570	380	56	504	
IEM5-**-3250/**-150-S-01	51	3250	117	150	70	2113	380	56	604	
IEM5-**-3250/**-200-S-01	68.1	3250	156	200	93.3	1585	380	56	604	
IEM5-**-3900/**-150-S-01	61.3	3900	141	150	70	2113	380	56	604	
IEM5-**-3900/**-200-S-01	81.7	3900	187	200	93.3	1585	380	56	604	

IEM5-***-02系列技术参数 (高速型)

型号	输出扭矩 S4(Nm)	额定电流 (A)	KT (Nm/A)	输出功率 (kW)	额定转速 (rpm)	额定频率 (Hz)	电压等级 (V)	反电势 (V)	极数	匹配驱动器型号 推荐	动力线缆规格 推荐
IEM5-03-600/A-320-Y-02	600	50.5	11.88	20.1	320	85.3	380	286	32	IMS-GL6-4018A	3×10mm ²
IEM5-06-750/A-320-Y-02	750	63.1	11.88	25.1	320	85.3	380	286	32	IMS-GL6-4022A	3×16mm ²
IEM5-06-1000/A-320-Y-02	1000	84.2	11.88	33.5	320	85.3	380	286	32	IMS-GL6-4030A	3×16mm ²

IEM5-***-01系列外形安装尺寸

型号	花键规格代码	花键规格	D	A	K	N	C	H	T	M	E	n-φd	φB	S
IEM5-03-***-01	A1	8-36b12×32b12×6f8	38	114	M12深30	190	79	35	14	210	280	5-φ13.5	φ20	15
IEM5-06-***-01	A2	8-42b12×36b12×7f8	43	127	M14深30	230	90	37	15	254	280	5-φ13.5	φ24	17
IEM5-08-***-01	A3	8-50b12×46b12×9f8	52	140	M14深30	256	103	37	15	300	330	5-φ17.5	φ26	20
IEM5-11-***-01	A4	8-54b12×46b12×9f8	52	140	M14深30	256	103	37	15	300	330	5-φ17.5	φ26	20
IEM5-03-***-01	A1	8-36b12×32b12×6f8	38	114	M12深30	190	79	35	14	210	\	5-φ13.5	φ20	15
IEM5-06-***-01	A2	8-42b12×36b12×7f8	43	127	M14深30	230	90	37	15	254	\	5-φ13.5	φ24	17
IEM5-08-***-01	A3	8-50b12×46b12×9f8	52	140	M14深30	256	103	37	15	300	\	5-φ17.5	φ26	20
IEM5-11-***-01	A4	8-54b12×46b12×9f8	52	140	M14深30	256	103	37	15	300	\	5-φ17.5	φ26	20
IEM5-16-***-01	A5	8-72b12×62b12×12f8	70	195	M16深30	301.5	148	47	10	327	\	5-φ22	φ33	24
IEM5-16-***-01	A5	8-72b12×62b12×12f8	70	195	M16深30	301.5	148	47	10	327	\	5-φ22	φ33	24
IEM5-31-***-01	A6	10-92b12×82b12×12f8	80	223.5	M20深30	380	166.5	57	10	420	\	5-φ26	φ40	32

IEM5-***-02系列外形安装尺寸

型号	E	I	L	L1	花键规格
IEM5-03-600/A-320-Y-02	104	38	379	148	8-38b12×32b12×6f8
IEM5-06-750/A-320-Y-02	124	46	379	148	8-42b12×36b12×7f8
IEM5-06-1000/A-320-Y-02	124	46	429	198	8-42b12×36b12×7f8

IEM5-***-01系列外形图

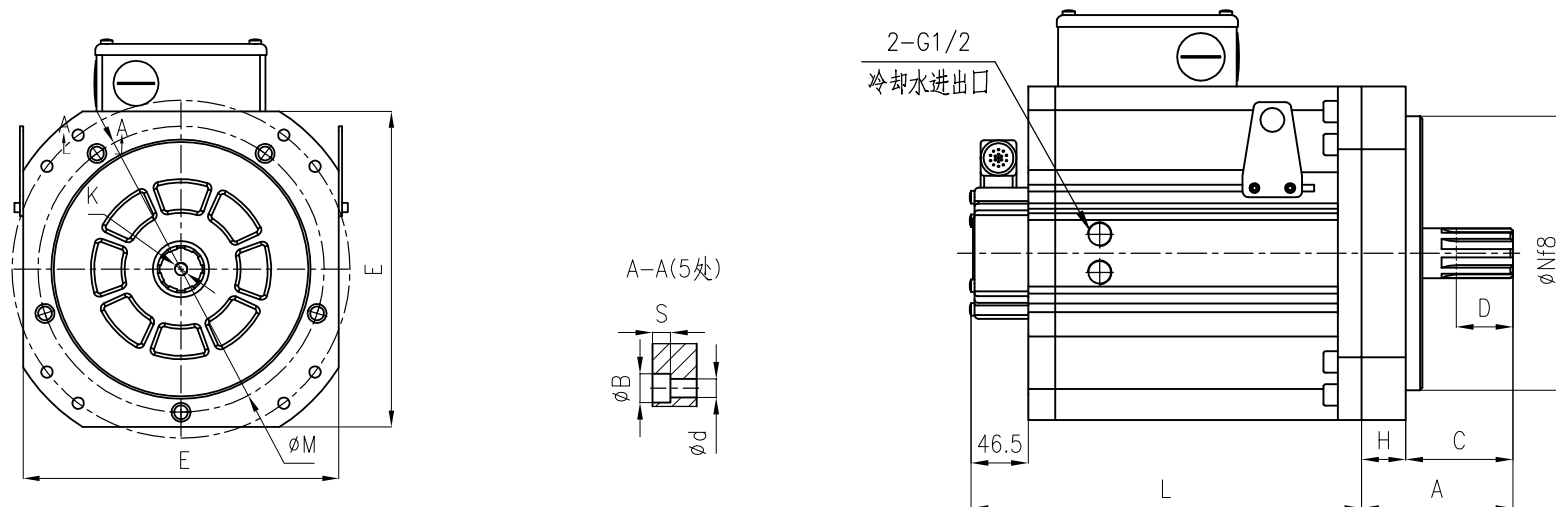

IEM5-***-02系列外形图

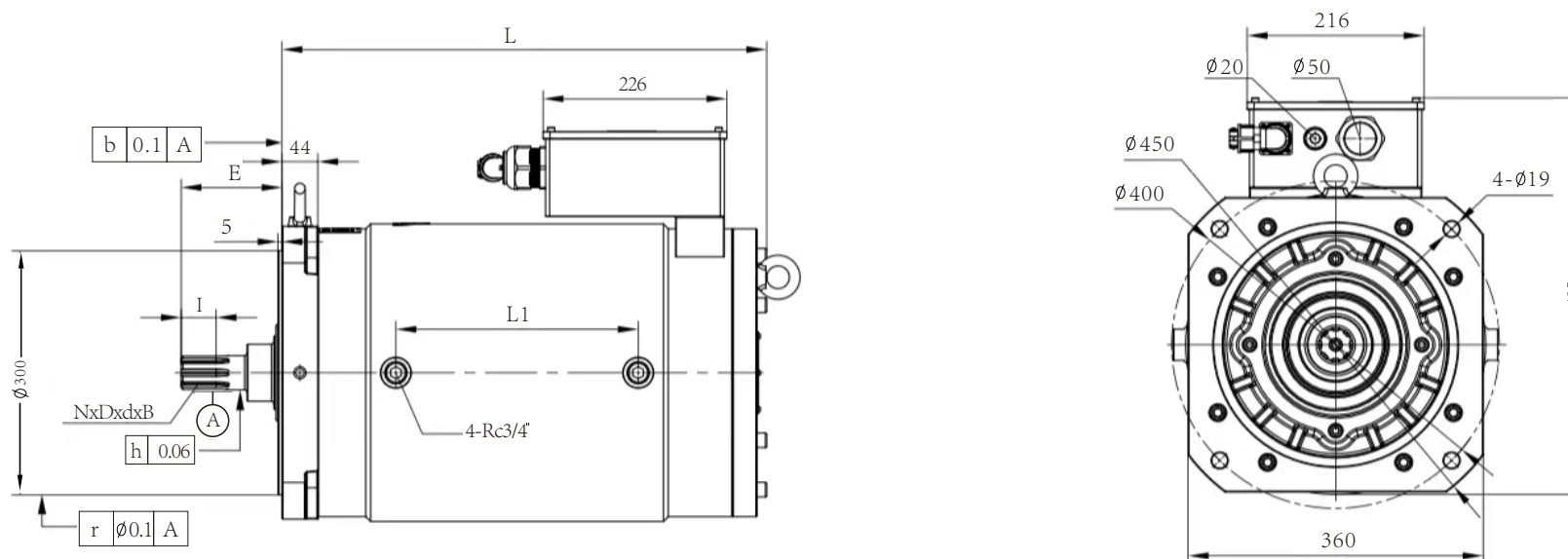

版权所有翻版必究
All RIGHT RESERVED
VER: 0IL-24-01/1010

<http://www.intermot.com.cn> www.nhm.com.cn

宁波欧易液压有限公司

NINGBO OIL CONTROL HYDRAULIC CO., LTD.

宁波英特姆液压马达有限公司

NINGBO INTERMOT HYDRAULIC MOTOR CO., LTD.

地 址: 宁波市镇海区镇骆东路1258号
邮 编: 315207
销售热线: 0086-574-8626 2917
服务热线: 400-085-0086
传 真: 0086-574-8626 0912
E - mail: sales@chinaintermot.com.cn

广东办事处

地 址: 东莞市万江区蚬涌企石商业街振兴路8号133
邮 编: 523069
总 机: 0086-769-22178605
传 真: 0086-769-22709005
服务热线: 400-085-0086
E - mail: intermot@163.com